

HOOK AND END DETAIL C-C

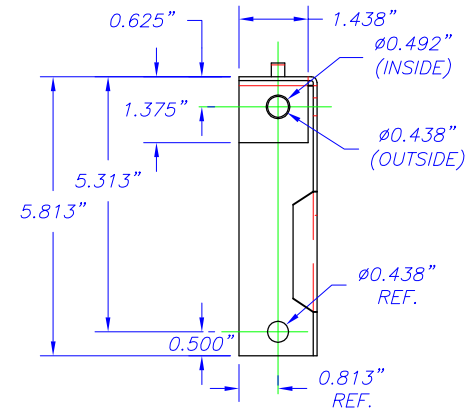
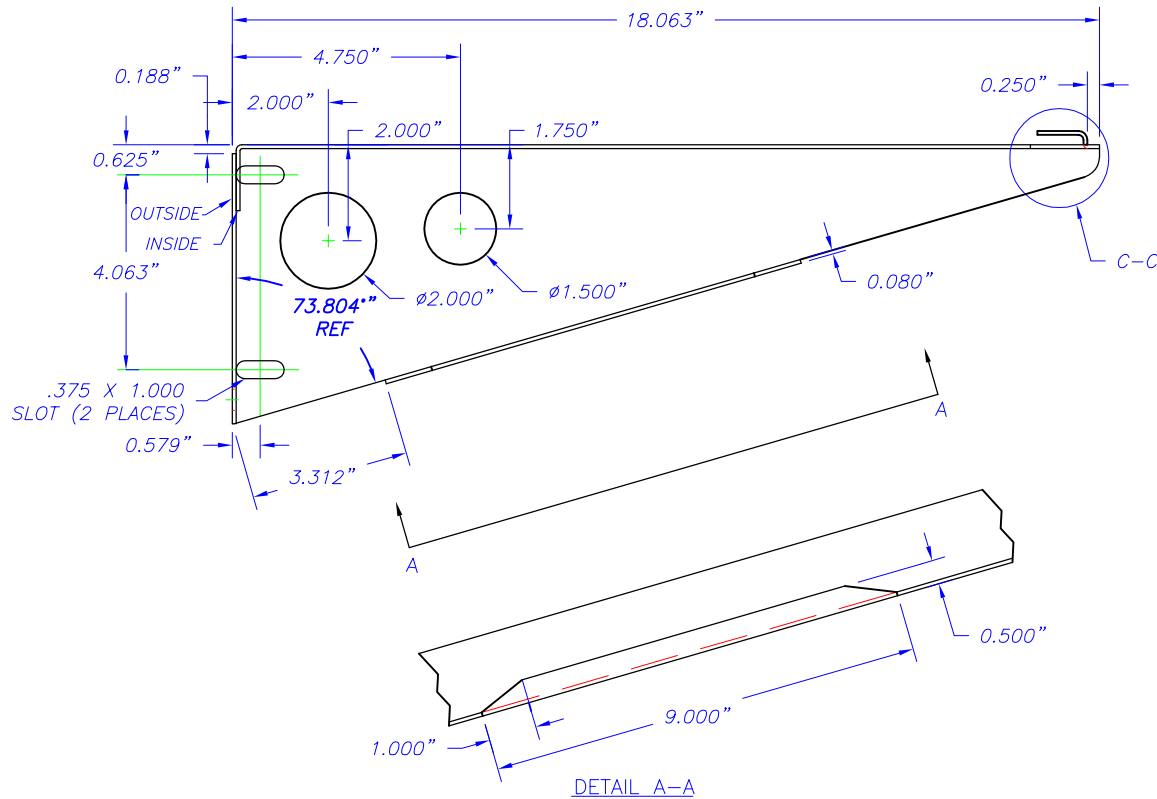

DETAIL B-B

**GENERAL NOTES:**

- 1) MATERIAL: COMMERCIAL QUALITY HOT ROLLED PICKLED AND OILED STEEL PER ASTM A569. MIN. YIELD =33 KSI.
- 2) DIMENSIONAL TOLERANCES:
  - A) GENERAL:  $\pm .03$ "
  - B) HOLE LOCATION:  $\pm .03$ "
  - C) HOLE DIAMETER:  $\pm .03$ "
- 3) MATERIAL THICKNESS (NOM): 2.0 MM
- 4) ALL UNITS IN INCHES U.N.O.
- 5) FINISH: PRE-GALVANIZED PER ASTM B633-SC1 TYPE 3.



This drawing in design and detail is the property of WBT, LLC. and must not be used except in connection with our work. All rights of design or invention are reserved.

PART # OR NAME		DRAWN BY	
Shelf Supt 18		RJM	
SIZE	DATE	SCALE	SHEET
A	4/22/16	3"=1'	1 OF 1
			REV
			N/A