

FLAT LAYOUT

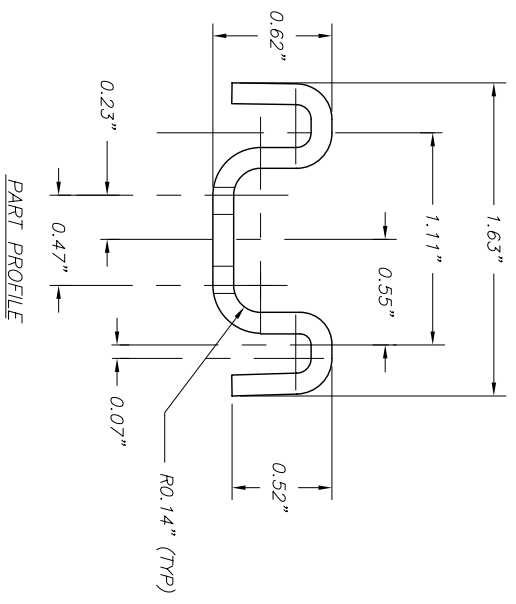
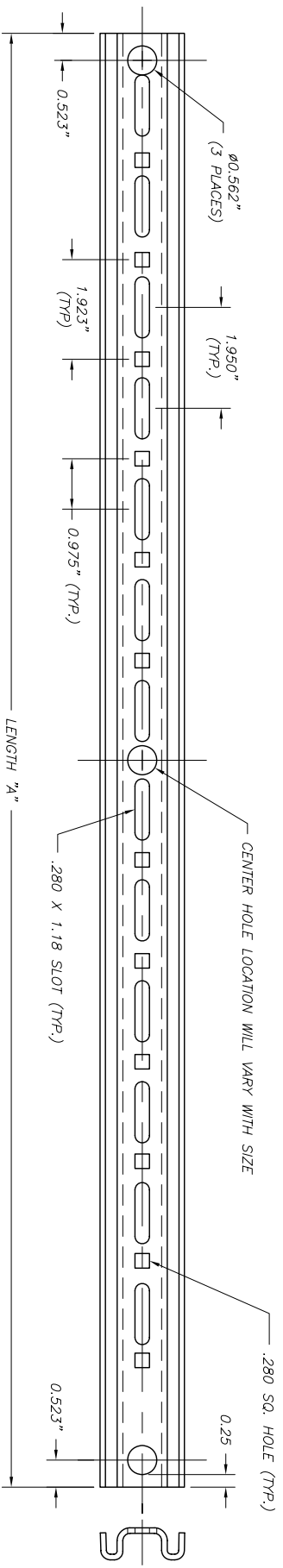

PART PROFILE

- GENERAL NOTES:
- 1) MATERIAL TO BE COMMERCIAL QUALITY MILL GALVANIZED STEEL PER ASTM A653 & A924 W/G-90 COATING MIN. YIELD = 33KSI.
 - 2) BLACK "FLEX-E-COAT" AFTER FABRICATION. PER ASTM B117 & NFPA 90A
 - 3) DIMENSIONAL TOLERANCES:
 - A) GENERAL .XX = ±1/16
 - B) HOLE LOCATION = ±.03
 - C) HOLE DIAMETER = ±.03
 - 4) MATERIAL THICKNESS (NOM) 12 GA = .1084
 - 5) ALL UNITS IN INCHES

ITEM	LENGTH "A"
12" PROFILE	12.490
16" PROFILE	16.390
24" PROFILE	24.190
28" PROFILE	28.090

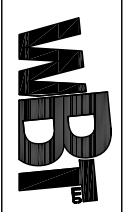

Desc: PROFILE SUPPORT	
Date: 7-28-08	Rev:
Drawn By: JD	Dwg #: PROFILE SUPPORT