

Item	Length "L"
4" L Bracket	4 21/32
8" L Bracket	8 9/16
12" L Bracket	12 7/16
16" L Bracket	16 11/32
20" L Bracket	20 1/4
24" L Bracket	25 5/32

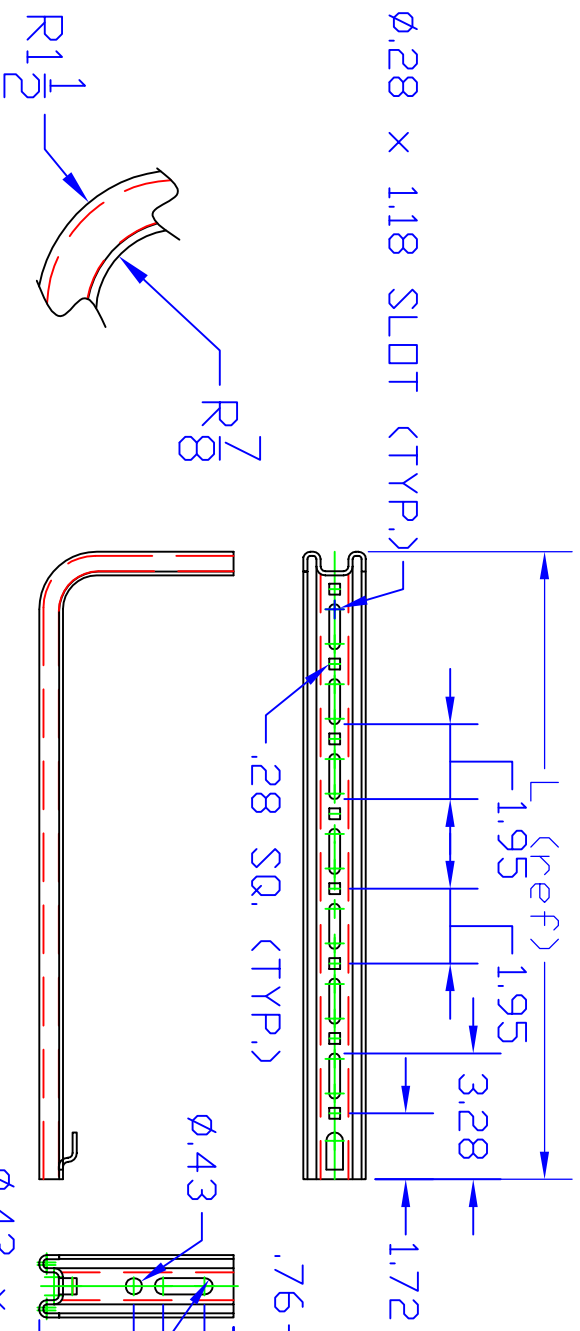

General Notes:

- 1) Material
 - A) Material to be commercial quality Mill galvanized steel per ASTM A653 & A924 W/G-90 Coating min. yield = 33KSI
 - B) Material to be commercial hot pickled & oiled steel per ASTM A569
- 2) dimensional Tolerances
 - A) General .xx = +/- 1/8
 - B) Hole Location = +/- .03
 - C) Hole Diameter = +/- .03
 - D) Angular +/- 2°
- 3) Material Thickness (NDM) 12GA. = .1084
- 4) All Angles to be 90° UNLD.
- 5) Finish: Electro-galvanized Per ASTM B633-SCI type 3
- 6) Min Bend Radius to be $\frac{1}{8}$ "

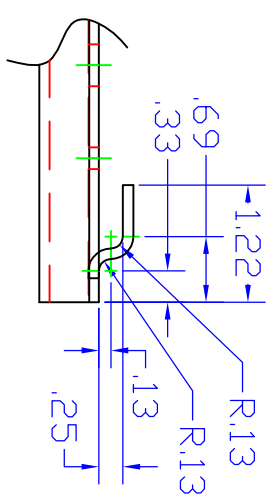
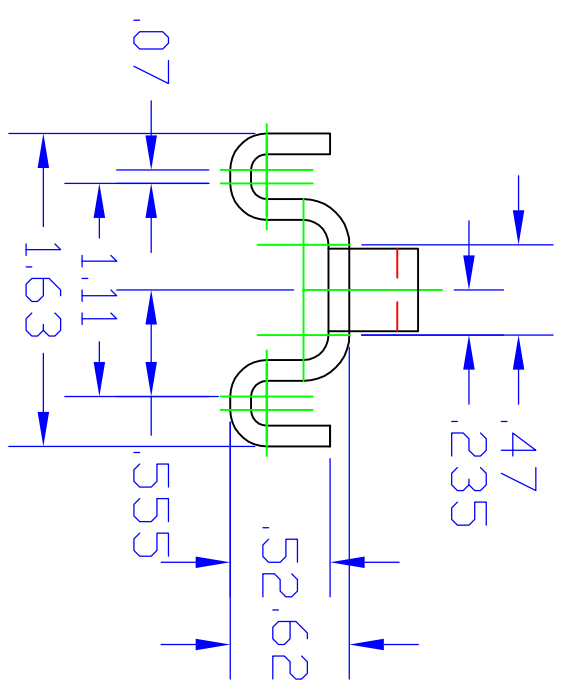

WBT LLC

L Bracket

SIZE: CN	DATE: A	SCALE:	SHEET:	REV:
3-31-09				

This drawing in design and detail is the property of WBT, LLC. and must be used except in connection with our work. All rights of design or invention are reserved.